



US 20160343944A1

(19) **United States**

(12) **Patent Application Publication**

LEE et al.

(10) **Pub. No.: US 2016/0343944 A1**

(43) **Pub. Date: Nov. 24, 2016**

(54) **MASKS, METHOD TO INSPECT AND ADJUST MASK POSITION, AND METHOD TO PATTERN PIXELS OF ORGANIC LIGHT-EMITTING DISPLAY DEVICE UTILIZING THE MASKS**

Publication Classification

(51) **Int. Cl.**
H01L 51/00 (2006.01)
H01L 27/32 (2006.01)
H01L 51/56 (2006.01)

(52) **U.S. Cl.**
 CPC *H01L 51/0011* (2013.01); *H01L 51/56* (2013.01); *H01L 27/3211* (2013.01); *H01L 51/5012* (2013.01)

(71) Applicant: **Samsung Display Co., Ltd.**, Yongin-si (KR)

(72) Inventors: **Sangshin LEE**, Yongin-si (KR); **Dongjin HA**, Yongin-si (KR); **Mingoo KANG**, Yongin-si (KR); **Ohseob KWON**, Yongin-si (KR); **Sangmin YI**, Yongin-si (KR)

(21) Appl. No.: **14/883,989**

(22) Filed: **Oct. 15, 2015**

(30) **Foreign Application Priority Data**

May 19, 2015 (KR) 10-2015-0069351

(57) **ABSTRACT**
 A method for pixel patterning and pixel position inspection of an organic light-emitting display device includes: forming, on a substrate using a first mask, a thin film layer of a first color corresponding to a first pixel pattern and a first pixel positioning pattern for inspecting a position of a first pixel; shifting, by a determined pitch, the first mask from a position associated with forming the thin film layer of the first color; aligning the shifted first mask with respect to the substrate; and forming, on the substrate using the shifted first mask, a thin film layer of a second color corresponding to the first pixel pattern and another first pixel positioning pattern for inspecting a position of a second pixel.

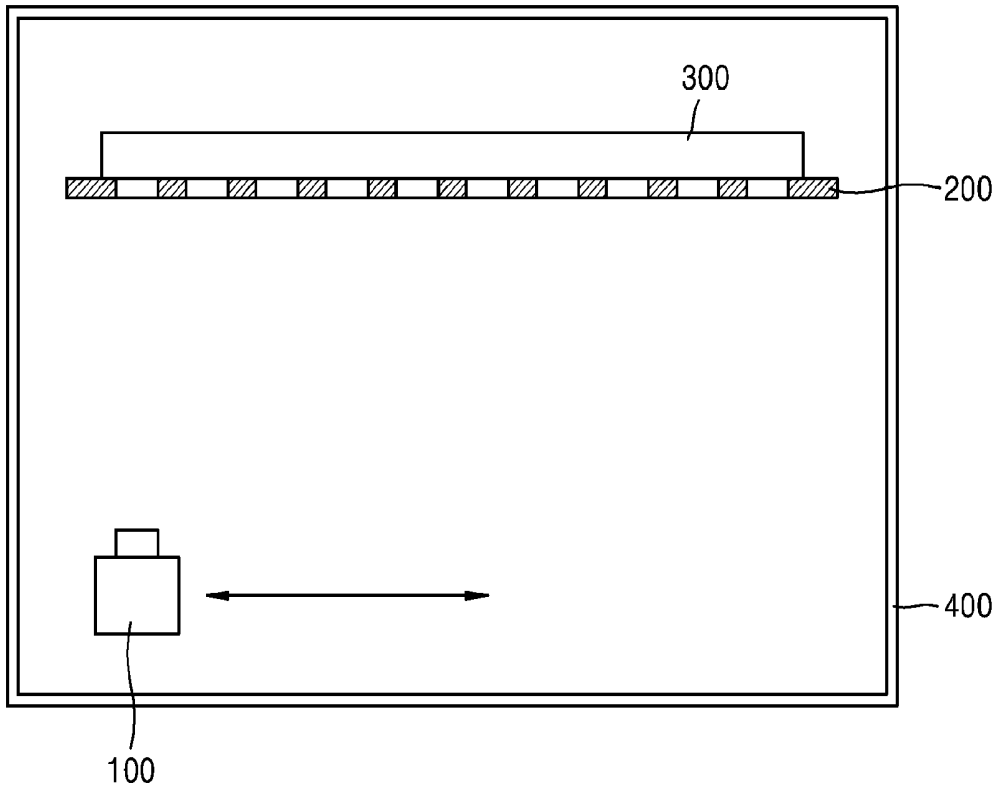

FIG. 1

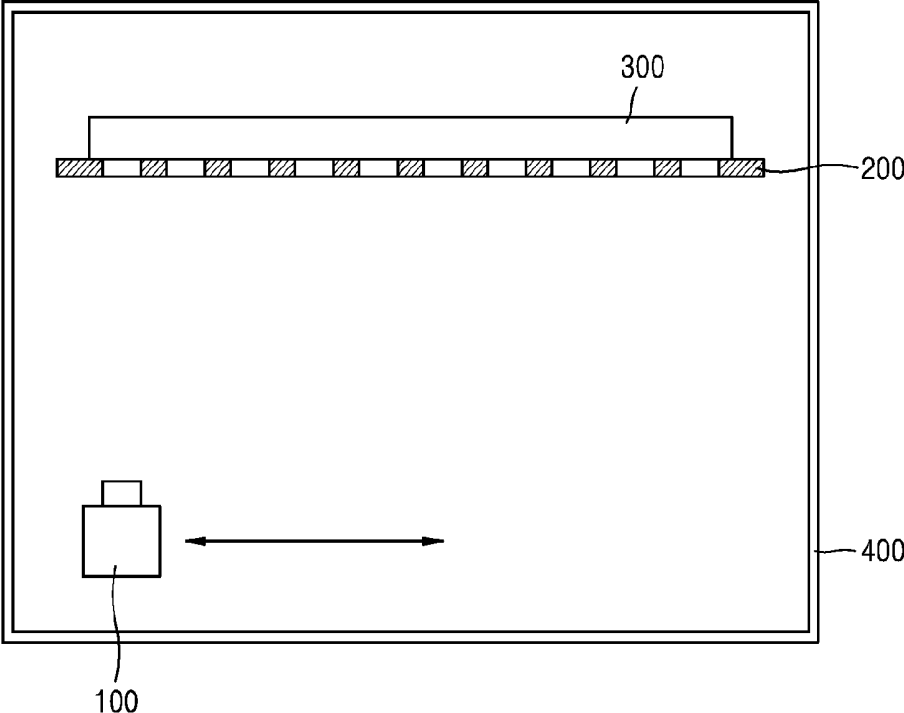

FIG. 2

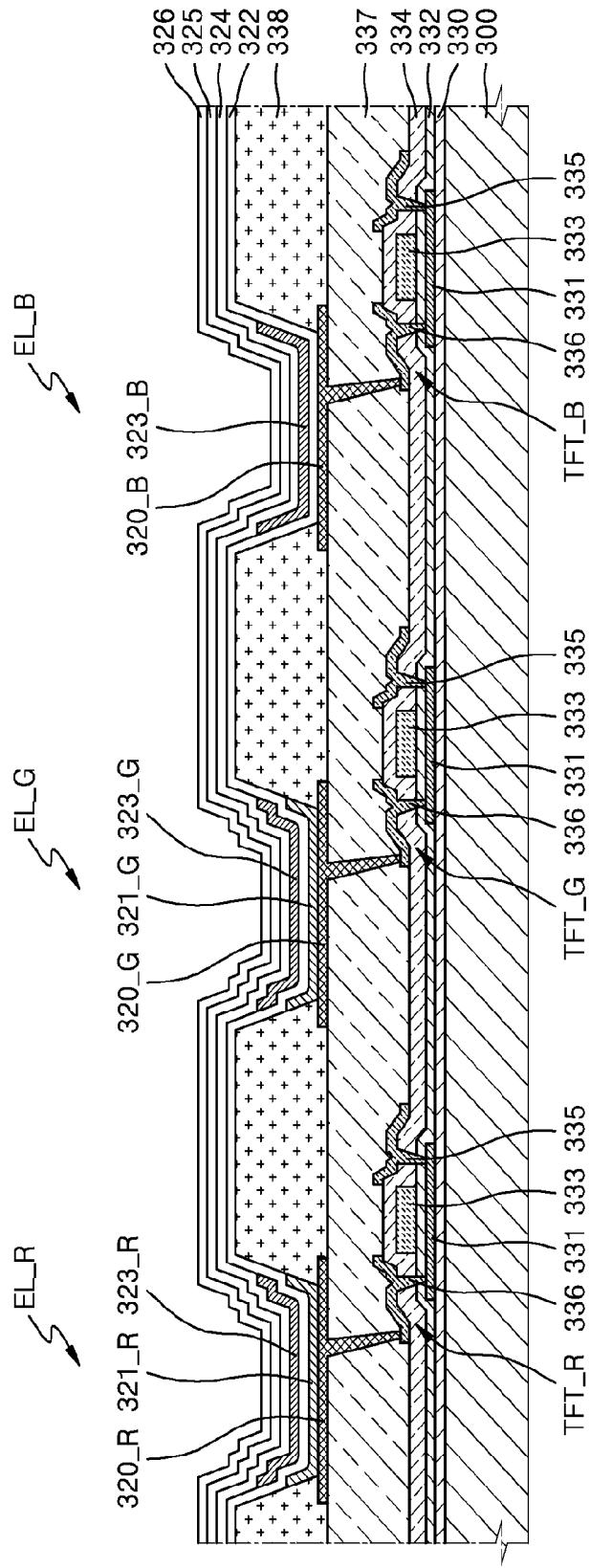

FIG. 3

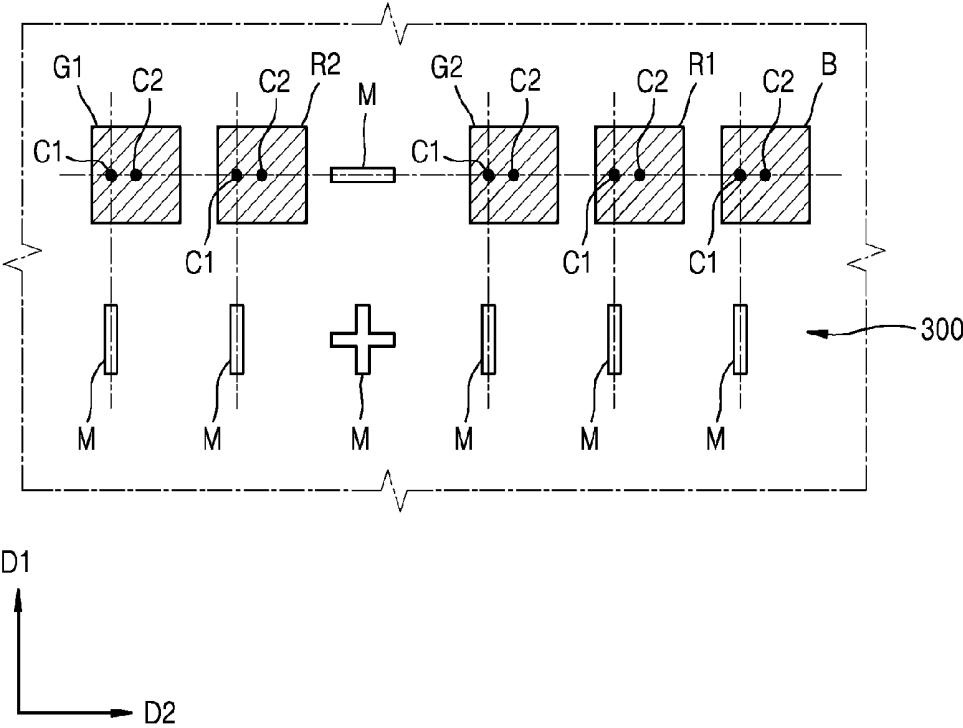

FIG. 4A

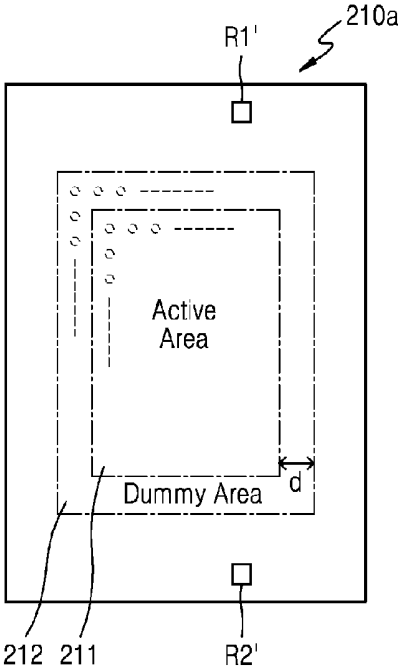

FIG. 4B

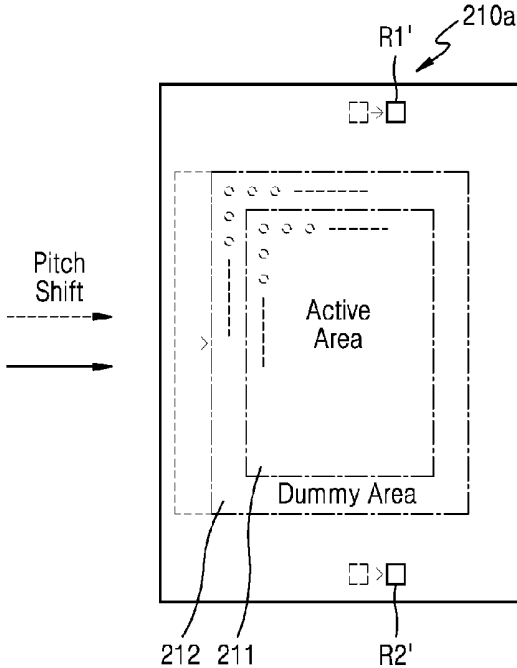

FIG. 4C

FIG. 4D

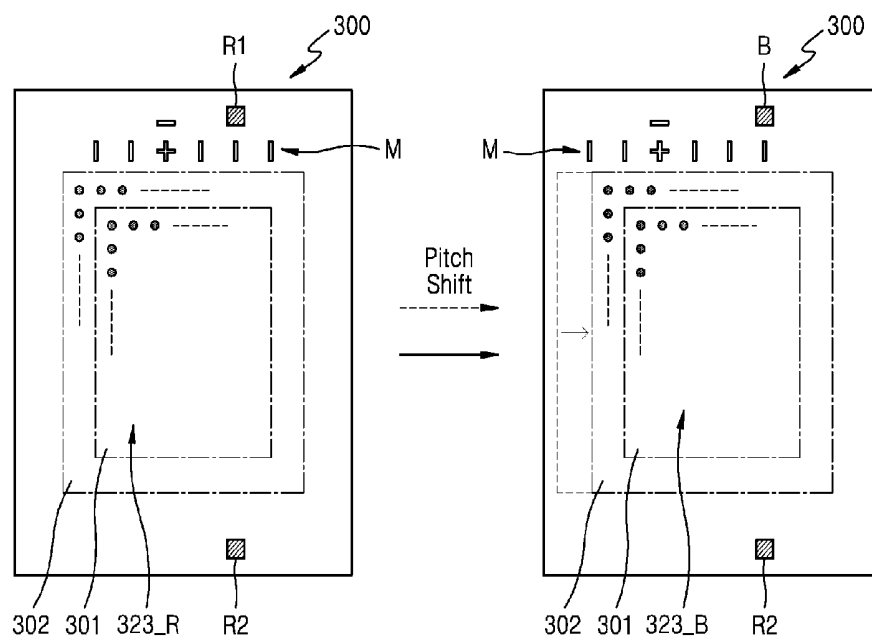

FIG. 5A

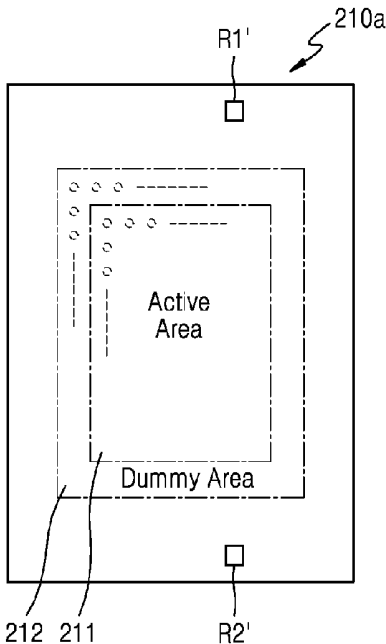

FIG. 5B

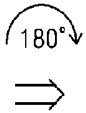
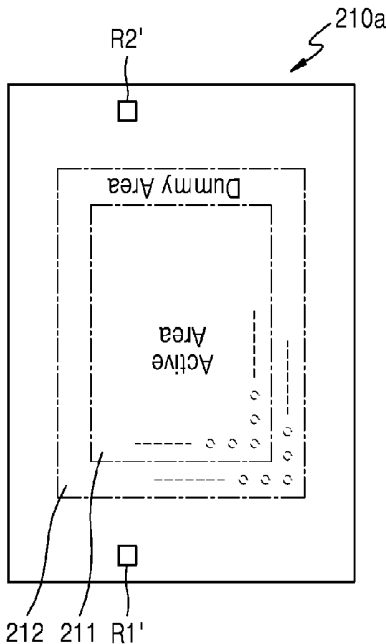

FIG. 5C

FIG. 5D

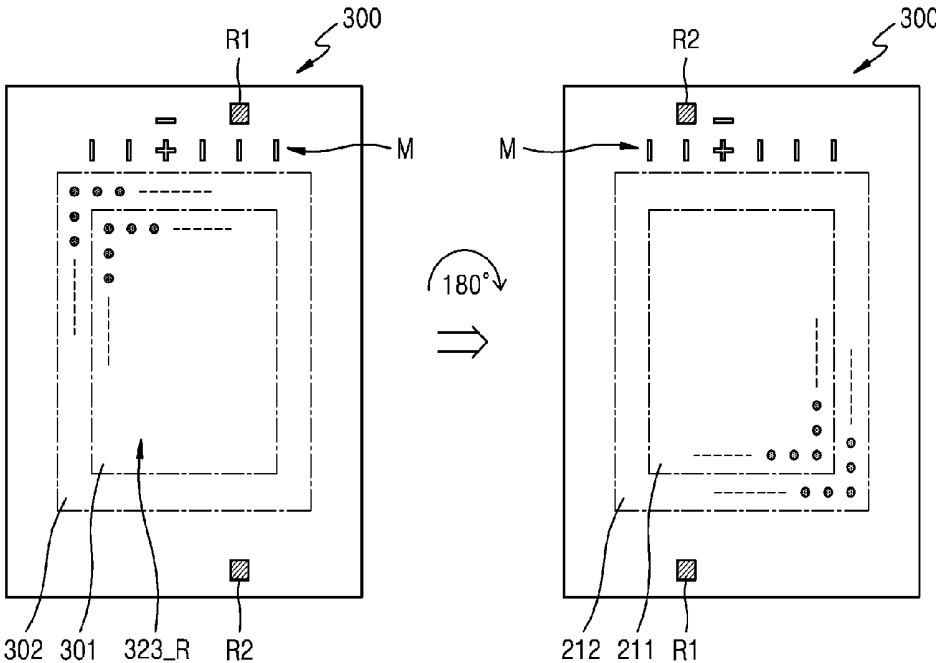

FIG. 6A

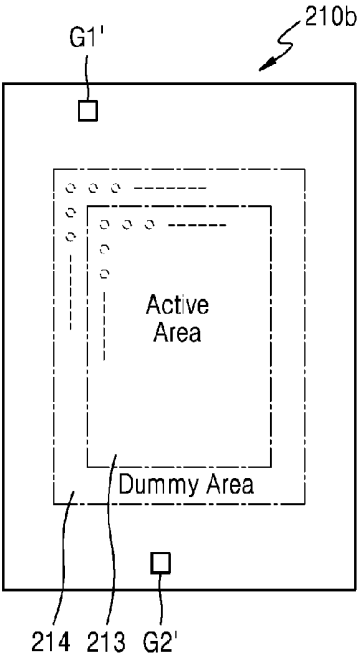

FIG. 6B

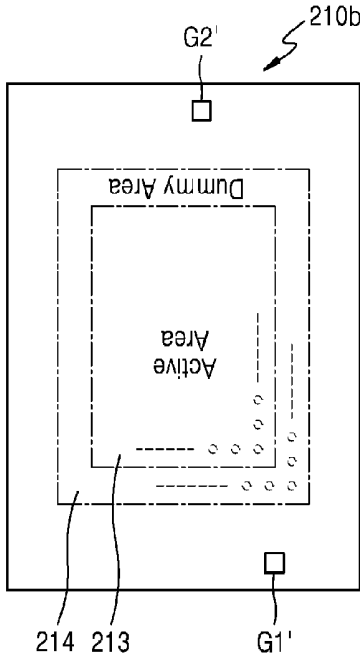
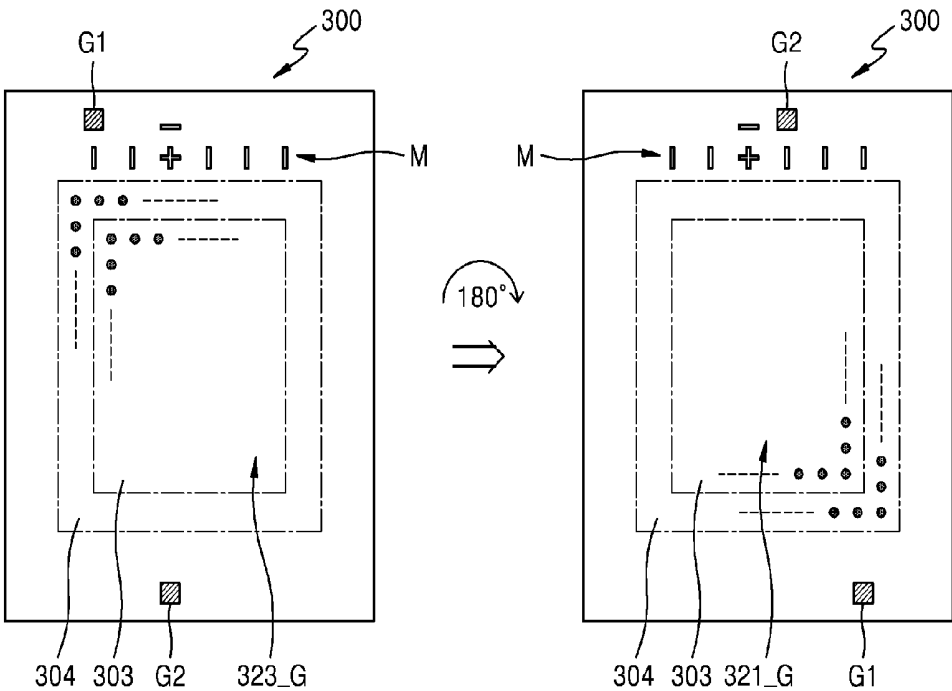

FIG. 6C

FIG. 6D



**MASKS, METHOD TO INSPECT AND
ADJUST MASK POSITION, AND METHOD
TO PATTERN PIXELS OF ORGANIC
LIGHT-EMITTING DISPLAY DEVICE
UTILIZING THE MASKS**

**CROSS-REFERENCE TO RELATED
APPLICATION**

[0001] This application claims priority from and the benefit of Korean Patent Application No. 10-2015-0069351, filed on May 19, 2015, which is incorporated by reference for all purposes as if fully set forth herein.

BACKGROUND

[0002] 1. Field

[0003] Exemplary embodiments relate to formation of thin films, and, more particularly, to a mask and a method of forming and inspecting the position accuracy of a thin film pattern via a deposition process utilizing the mask.

[0004] 2. Discussion

[0005] Vapor deposition typically involves generating vapor from a deposition source and allowing the vapor to adhere to a substrate surface. For instance, a mask may be disposed on (or over) a substrate, and vapor from a deposition source may be allowed to pass through openings in a mask and on the substrate to form a desired thin film pattern on the substrate. Such thin film manufacturing techniques may be used to form thin film pattern associated with flat panel display devices, such as an organic light-emitting device (OLED). For example, the thin film pattern may correspond to a thin film pixel pattern.

[0006] The above information disclosed in this Background section is only for enhancement of understanding of the background of the inventive concept, and, therefore, it may contain information that does not form the prior art that is already known in this country to a person of ordinary skill in the art.

SUMMARY

[0007] Exemplary embodiments provide a mask used to form a thin film pixel pattern for an organic light-emitting display device.

[0008] Exemplary embodiments provide a method for pixel patterning and inspecting pixel positioning in an organic light-emitting display device.

[0009] Additional aspects will be set forth in part in the description which follows, and, in part, will be apparent from the disclosure, or may be learned by practice of the inventive concept.

[0010] According to one or more exemplary embodiments, a method for pixel patterning and pixel position inspection of an organic light-emitting display device includes: forming, on a substrate using a first mask, a thin film layer of a first color corresponding to a first pixel pattern and a first pixel positioning pattern for inspecting a position of a first pixel; shifting, by a determined pitch, the first mask from a position associated with forming the thin film layer of the first color; aligning the shifted first mask with respect to the substrate; and forming, on the substrate using the shifted first mask, a thin film layer of a second color corresponding to the first pixel pattern and another first pixel positioning pattern for inspecting a position of a second pixel.

[0011] According to one or more exemplary embodiments, a pixel patterning mask for an organic light-emitting display device includes: a pixel pattern; a first inspection pattern for inspecting a first pixel position, the first inspection pattern being configured to facilitate measurement of position accuracy of a thin film layer formed on a substrate via the pixel pattern; and a second inspection pattern for inspecting a second pixel position, the second inspection pattern being configured to facilitate measurement of position accuracy of a thin film layer formed on the substrate via the pixel pattern. The second inspection pattern is formed in a different position than the first inspection pattern.

[0012] The foregoing general description and the following detailed description are exemplary and explanatory and are intended to provide further explanation of the claimed subject matter.

BRIEF DESCRIPTION OF THE DRAWINGS

[0013] The accompanying drawings, which are included to provide a further understanding of the inventive concept, and are incorporated in and constitute a part of this specification, illustrate exemplary embodiments of the inventive concept, and, together with the description, serve to explain principles of the inventive concept.

[0014] FIG. 1 is a schematic view of a thin film deposition apparatus, according to one or more exemplary embodiments.

[0015] FIG. 2 is a cross-sectional view of a unit pixel structure of an organic light-emitting display device that may be formed via the thin film deposition apparatus of FIG. 1, according to one or more exemplary embodiments.

[0016] FIG. 3 is a plan view of marks and thin film patterns formed on a substrate that may be utilized to accurately position a mask in association with a pixel for thin film deposition, according to one or more exemplary embodiments.

[0017] FIGS. 4A, 4B, 4C, and 4D illustrate a method of patterning an emission layer of a first pixel and an emission layer of a second pixel using a first mask, according to one or more exemplary embodiments.

[0018] FIGS. 5A, 5B, 5C, and 5D illustrate a method of patterning an emission layer of a first pixel and an auxiliary layer of the first pixel using the first mask of FIGS. 4A, 4B, 4C, and 4D, according to one or more exemplary embodiments.

[0019] FIGS. 6A, 6B, 6C, and 6D illustrate a method of patterning an emission layer of a third pixel and an auxiliary layer of the third pixel using a second mask, according to one or more exemplary embodiments.

**DETAILED DESCRIPTION OF THE
ILLUSTRATED EMBODIMENTS**

[0020] In the following description, for the purposes of explanation, numerous specific details are set forth in order to provide a thorough understanding of various exemplary embodiments. It is apparent, however, that various exemplary embodiments may be practiced without these specific details or with one or more equivalent arrangements. In other instances, well-known structures and devices are shown in block diagram form in order to avoid unnecessarily obscuring various exemplary embodiments.

[0021] In the accompanying figures, the size and relative sizes of layers, films, panels, regions, etc., may be exaggerated

ated for clarity and descriptive purposes. Also, like reference numerals denote like elements.

[0022] When an element or layer is referred to as being “on,” “connected to,” or “coupled to” another element or layer, it may be directly on, connected to, or coupled to the other element or layer or intervening elements or layers may be present. When, however, an element or layer is referred to as being “directly on,” “directly connected to,” or “directly coupled to” another element or layer, there are no intervening elements or layers present. For the purposes of this disclosure, “at least one of X, Y, and Z” and “at least one selected from the group consisting of X, Y, and Z” may be construed as X only, Y only, Z only, or any combination of two or more of X, Y, and Z, such as, for instance, XYZ, XYY, YZ, and ZZ. Like numbers refer to like elements throughout. As used herein, the term “and/or” includes any and all combinations of one or more of the associated listed items.

[0023] Although the terms “first,” “second,” etc. may be used herein to describe various elements, components, regions, layers, and/or sections, these elements, components, regions, layers, and/or sections should not be limited by these terms. These terms are used to distinguish one element, component, region, layer, and/or section from another element, component, region, layer, and/or section. Thus, a first element, component, region, layer, and/or section discussed below could be termed a second element, component, region, layer, and/or section without departing from the teachings of the present disclosure.

[0024] Spatially relative terms, such as “beneath,” “below,” “lower,” “above,” “upper,” and the like, may be used herein for descriptive purposes, and, thereby, to describe one element or feature’s relationship to another element(s) or feature(s) as illustrated in the drawings. Spatially relative terms are intended to encompass different orientations of an apparatus in use, operation, and/or manufacture in addition to the orientation depicted in the drawings. For example, if the apparatus in the drawings is turned over, elements described as “below” or “beneath” other elements or features would then be oriented “above” the other elements or features. Thus, the exemplary term “below” can encompass both an orientation of above and below. Furthermore, the apparatus may be otherwise oriented (e.g., rotated 90 degrees or at other orientations), and, as such, the spatially relative descriptors used herein interpreted accordingly.

[0025] The terminology used herein is for the purpose of describing particular embodiments and is not intended to be limiting. As used herein, the singular forms, “a,” “an,” and “the” are intended to include the plural forms as well, unless the context clearly indicates otherwise. Moreover, the terms “comprises,” “comprising,” “includes,” and/or “including,” when used in this specification, specify the presence of stated features, integers, steps, operations, elements, components, and/or groups thereof, but do not preclude the presence or addition of one or more other features, integers, steps, operations, elements, components, and/or groups thereof. Unless stated otherwise, a specific process order may be performed differently than described. For example, two consecutively described processes may be performed substantially at the same time or performed in an order opposite to the described order.

[0026] Various exemplary embodiments are described herein with reference to sectional illustrations that are sche-

matic illustrations of idealized exemplary embodiments and/or intermediate structures. As such, variations from the shapes of the illustrations as a result, for example, of manufacturing techniques and/or tolerances, are to be expected. Thus, exemplary embodiments disclosed herein should not be construed as limited to the particular illustrated shapes of regions, but are to include deviations in shapes that result from, for instance, manufacturing. For example, an implanted region illustrated as a rectangle will, typically, have rounded or curved features and/or a gradient of implant concentration at its edges rather than a binary change from implanted to non-implanted region. Likewise, a buried region formed by implantation may result in some implantation in the region between the buried region and the surface through which the implantation takes place. Thus, the regions illustrated in the drawings are schematic in nature and their shapes are not intended to illustrate the actual shape of a region of a device and are not intended to be limiting.

[0027] Unless otherwise defined, all terms (including technical and scientific terms) used herein have the same meaning as commonly understood by one of ordinary skill in the art to which this disclosure is a part. Terms, such as those defined in commonly used dictionaries, should be interpreted as having a meaning that is consistent with their meaning in the context of the relevant art and will not be interpreted in an idealized or overly formal sense, unless expressly so defined herein.

[0028] FIG. 1 is a schematic view of a thin film deposition apparatus, according to one or more exemplary embodiments.

[0029] As seen in FIG. 1, the thin film deposition apparatus includes a mask 200 for forming a desired pattern on a substrate 300, which is a deposition object, and a deposition source unit 100. The deposition source unit 100 may be configured to reciprocate back and forth inside a chamber 400 and to spray (or otherwise release) a deposition gas toward the substrate 300. Accordingly, when the deposition source unit 100 sprays the deposition gas inside the chamber 400, the deposition gas may pass through openings formed in the mask 200 and may be deposited on the substrate 300 to form a thin film in a determined pattern.

[0030] FIG. 2 is a cross-sectional view of a unit pixel structure of an organic light-emitting display device that may be formed via the thin film deposition apparatus of FIG. 1, according to one or more exemplary embodiments. For example, substrate 300 of FIG. 1 may be substrate 300 of the organic light-emitting display device of FIG. 2. The unit pixel may include three color sub-pixels, e.g., a red (R) sub-pixel, a green (G) sub-pixel, and a blue (B) sub-pixel. It is contemplated, however, that any suitable color and number of sub-pixels may be formed utilized in association with exemplary embodiments described herein. For descriptive convenience, the various sub-pixels of the unit pixel will, hereinafter, be referred to as pixels.

[0031] Referring to FIG. 2, the unit pixel may include a buffer layer 330 formed on the substrate 300, a thin film transistor TFT_R for a red pixel R, a thin film transistor TFT_G for a green pixel G, and a thin film transistor TFT_B for a blue pixel B disposed on a surface (e.g., an upper surface) of the buffer layer 330. Each of the thin film transistors TFT_R, TFT_G, and TFT_B may include a semiconductor active layer 331, a gate insulating layer 332 covering the semiconductor active layer 331, and a gate

electrode **333** disposed on the gate insulating layer **332**, e.g., on an upper surface of the gate insulating layer **332**. An interlayer insulating layer **334** is formed to cover the gate electrode **333**. A source electrode **335** and a drain electrode **336** are formed on the upper portion of the interlayer insulating layer **334**. The source electrode **335** and the drain electrode **336** contact a source region and a drain region of the semiconductor active layer **331**, respectively, via corresponding contact holes formed in the gate insulating layer **332** and the interlayer insulating layer **334**.

[0032] Corresponding pixel electrodes **320_R**, **320_G**, and **320_B** of respective organic light-emitting devices EL_R, EL_G, and EL_B are connected to the source electrodes **335** and drain electrodes **336** of the color pixels, respectively. The respective pixel electrodes **320_R**, **320_G**, and **320_B** may be formed on a planarization layer **337**. A pixel-defining layer **338** may cover the pixel electrodes **320_R**, **320_G**, and **320_B**. An interlayer including emission layers **323_R**, **323_G**, and **323_B** and an auxiliary layer is formed on the pixel electrodes **320_R**, **320_G**, and **320_B**. An opposite electrode **326** is formed on the respective interlayers.

[0033] The auxiliary layer includes hole injection layers **321_R** and **321_G**, a hole transport layer **322**, an electron transport layer **324**, and an electron injection layer **325**. As seen in FIG. 2, the hole injection layers **321_R** and **321_G** are not disposed in association with the blue pixel B, but are disposed in association with the red pixel R and the green pixel G. The hole injection layers **321_R** and **321_G** are disposed in association with the emission layers **323_R** and **323_G**. In this manner, the emission layers **323_R** and **323_G** overlap the hole injection layers **321_R** and **321_G**. As with the opposite electrode **326**, the hole transport layer **322**, the electron transport layer **324**, and the electron injection layer **325** are common layers formed in association with each pixel region. As such, the opposite electrode **326**, the hole transport layer **322**, the electron transport layer **324**, and the electron injection layer **325** may be formed via an open mask without any specific pattern or, in other words, may be formed to cover an entire surface of an underlying layer on the substrate **300**. The emission layer **323_R** of the red pixel R and the emission layer **323_B** of the blue pixel B have the same pattern, but are spaced apart from one another by a determined pitch corresponding to an interval between the red pixel R and the blue pixel B.

[0034] According to one or more exemplary embodiments, a method is provided to form the emission layers **323_R**, **323_G**, and **323_B** and the hole injection layers **321_R** and **321_G** in accurate positions, with accurate patterning, and with accurate overlapping conditions. In this manner, a mask utilized to form the emission layers **323_R** and **323_B** may be different than the mask utilized to form the emission layer **323_G**. Furthermore, one or more masks utilized to form the hole injection layers **321_R** and **321_G** may not be utilized to form a portion of the blue pixel B, as the blue pixel B does not include a hole injection layer. To this end, the emission layers **323_R**, **323_G**, and **323_B** and the hole injection layers **321_R** and **321_G** should be patterned at an accurate positions in each pixel. When, however, a mask is not at an accurate position, the position of a thin film deposited on the substrate **300** may be offset from an expected position and this may reduce the display quality of the pixel. To help prevent (or at least reduce) the potential for such an offset of a mask, the method may

include a process of accurately measuring a pixel position to accurately deposit a thin film in association therewith.

[0035] FIG. 3 is a plan view of marks and thin film patterns formed on a substrate that may be utilized to accurately position a mask in association with a pixel for thin film deposition, according to one or more exemplary embodiments.

[0036] To measure for deposition position accuracy, marks M (as shown in FIG. 3) may be formed on a first side of a substrate **300**, and patterns G1', R1', G2', and R2' (as shown in FIGS. 4A and 6A) may be utilized to form thin film layers G1, R1, B, G2, and R2 for inspection. Thin film layers G1, R1, B, G2, and R2 may be formed on reference central points C1 that are aligned in a first direction D1 with virtual extension lines extending from the marks M. In this manner, when the emission layers **323_R**, **323_G**, and **323_B** and the hole injection layers **321_R** and **321_G** are formed, the thin film layers G1, R1, B, G2, and R2 for inspection may also be deposited and formed on the substrate **300**. Accordingly, when the mask is accurately positioned, central points C2 of the thin film layers G1, R1, B, G2, and R2 for inspection will coincide with the reference central points C1 that are associated with the marks M. However, when the mask is not accurately positioned, and, thereby, offset in, for instance, a second direction D2, the central points C2 of the thin film layers G1, R1, B, G2, and R2 for inspection will not coincide with the reference central points C1 associated with the marks M. Instead, a gap interval in the second direction D2 will exist between the reference central points C1 and the central points C2 as exemplified in FIG. 3. The gap interval may be measured as an offset misalignment of the mask. The measured gap interval may be utilized to reposition the mask so that the offset may be removed for a next deposition process.

[0037] Although not illustrated, it is also contemplated that one or more marks may be formed on a second side of the substrate **300** that is perpendicular (or substantially perpendicular) to the first side of the substrate **300** (or formed in another portion of the substrate) to measure and adjust for positioning accuracy associated with the first direction D1. That is, a gap interval may also be measured in the first direction D1 based on an offset of the reference central point C1 and the central point C2 in the first direction D1. In this manner, the mask may be accurately positioned in both the first direction D1 and the second direction D2.

[0038] An exemplary method to form the emission layers **323_R**, **323_G**, and **323_B**, the hole injection layers **321_R** and **321_G**, and respective thin film layers G1, R1, B, G2, and R2 for inspection will be described in association with FIGS. 4A, 4B, 4C, 4D, 5A, 5B, 5C, 5D, 6A, 6B, 6C, and 6D.

[0039] FIGS. 4A, 4B, 4C, and 4D illustrate a method of patterning an emission layer of a first pixel and an emission layer of a second pixel using a first mask, according to one or more exemplary embodiments. For instance, the emission layer of the first pixel may be emission layer **323_R** of a red pixel R and the emission layer of the second pixel may be emission layer **323_B** of a blue pixel B. To this end, the first mask will be referred to as mask **210a**.

[0040] As illustrated in FIGS. 4A and 4B, the first mask **210a** may include first pixel patterns in an active area **211** and a dummy area **212** disposed outside the active area **211**, a pattern R1' for inspecting a first pixel position, and a pattern R2' for inspecting a second pixel position. The active area **211** is a pattern region for actually forming the emission

layers 323_R, 323_G, and 323_B and the hole injection layers 321_R and 321_G. The dummy area 212 is a marginal pattern region disposed outside the active area 211, e.g., surrounding the active area 211. The pattern R1' for inspecting the first pixel position is a pattern for forming a thin film layer R1 for a first inspection, as seen in FIG. 4C. The pattern R1' is formed when the emission layer 323_R of a pixel R is formed. The pattern R2' for inspecting the second pixel position is a pattern for forming a thin film layer R2 for a third inspection, as seen in FIGS. 4C and 4D.

[0041] According to one or more exemplary embodiments, the pattern R2' for inspecting the second pixel position may not be used during a process of forming the emission layer 323_R of the red pixel R and the emission layer 323_B of the blue pixel B. For example, the pattern R2' for inspecting the second pixel position may be an opening formed in the first mask 210a, and, as such, the thin film layer R2 for a third inspection is formed on the substrate 300 during the deposition process shown in FIGS. 4C and 4D. It is noted, however, that the thin film layer R2 for the third inspection is formed at a location different from the marks M, such that the thin film layer R2 for the third inspection is not used for the first inspection. Further, the thin film layer R2 will not interfere with the first inspection.

[0042] When the emission layer 323_R of the red pixel R is formed using the first mask 210a, the first mask 210a is aligned on the substrate 300 and deposition is performed as seen in FIG. 4A. In this manner, thin film layers 301, 302, R1, and R2 of a red (R) color (hereinafter referred to as a first color) are formed on the substrate 300, as seen in FIG. 4C. An active area 301 and a dummy area 302 of the thin film layers of the first color are formed on areas of the substrate 300 that correspond to the first pixel patterns in the active area 211 and the dummy area 212 of the first mask 210a, respectively. Thin film layers R1 and R2 for the first inspection and the third inspection are formed on areas corresponding to the patterns R1' and R2' for inspecting the first and second pixel positions of the first mask 210a, respectively. The thin film layer corresponding to the active area 301 will become the emission layer 323_R of the red pixel R.

[0043] To inspect whether the thin film layers 301, 302, R1, and R2 of the first color including the emission layer 323_R of the red pixel R are accurately formed, the positions of the thin film layer R1 for the first inspection and the central points C1 and C2 associated with the marks M are compared as described with reference to FIG. 3. When it is determined that an offset of the first mask 210a exists as a result of the comparison, the position of the first mask 210a is adjusted so that the offset may be eliminated (or at least reduced) when the next thin film layers 301, 302, R1, and R2 of the first color are formed.

[0044] According to one or more exemplary embodiments, first mask 210a is used to form the emission layer 323_R of the pixel R may be used even when the emission layer 323_B of the pixel B is formed. It is contemplated, however, that the first mask 210a may be used to form the emission layer 323_R of the red pixel R, but not used to form the emission layer 323_B of the blue pixel B. In this manner, another first mask 210a may be used.

[0045] As illustrated in FIG. 4A, the first mask 210a is disposed over the substrate 300, and, as seen in FIG. 4B, the first mask 210a is shifted by a determined pitch and aligned with the substrate 300 based, at least in part, on the formation of the emission layer 323_R of the red pixel R. That is,

because the emission layer 323_R of the red pixel R and the emission layer 323_B of the blue pixel B have the same pattern that would otherwise overlap each other if the emission layer 323_R of the red pixel R were moved by a determined pitch over the emission layer 323_B of the blue pixel B, the first mask 210a may be moved by the determined pitch to form the emission layer 323_B of the blue pixel B. As such, when the first mask 210a, which is used to form the emission layer 323_R of the red pixel R, is shifted by the determined pitch, the pattern of the emission layer 323_R of the red pixel R may be formed as the emission layer 323_B of the blue pixel B. The shift distance may be adjusted by 1 pitch, 3 pitches, etc., by taking into account the determined pitch. To this end, it is noted that the shifting of first mask 210a should be performed in a shifting direction within a width "d" of the dummy area.

[0046] Accordingly, as seen in FIG. 4B, when the first mask 210a is shifted by the determined pitch with respect to the substrate 300, the first pixel patterns of the active area and the dummy area 211 and 212 and the patterns R1' and R2' for inspecting the first and second pixel positions will also be shifted and aligned. As such, when a deposition process is performed, thin film layers 301, 302, B, and R2 of a blue (B) color (referred to hereinafter as a second color) are formed and are shifted from the thin film layers of the first color by the determined pitch, as seen by comparing FIGS. 4C and 4D. An active area 301 and a dummy area 302 of the thin film layers of the second color are formed on areas of the substrate 300 that correspond to the first pixel patterns of the active area 211 and the dummy area 212 of the first mask 210a, respectively. To this end, the thin film layer B for a second inspection and the thin film layer R2 for a third inspection are formed on areas that correspond to the patterns R1' and R2' for inspecting the first and second pixel positions of the first mask 210a, respectively. In this manner, the thin film layer corresponding to the active area 301 will become the emission layer 323_B of the blue pixel B.

[0047] To inspect whether the thin film layers 301, 302, B, and R2 of the second color and the emission layer 323_B of the blue pixel B are accurately formed, the positions of the thin film layer B of the second inspection and the central points C1 and C2 associated with the marks M are compared with each other as described with reference to FIG. 3. When it is determined that an offset of the first mask 210a exists as a result of the comparison, the position of the first mask 210a may be adjusted so that the offset may be canceled (or at least reduced) when the next thin film layers 301, 302, B, and R2 of the second color are formed.

[0048] The first mask 210a may also be used to form the hole injection layer 321_R, which is an auxiliary layer of the red pixel R.

[0049] FIGS. 5A, 5B, 5C, and 5D illustrate a method of patterning an emission layer of a first pixel and an auxiliary layer of the first pixel using the first mask of FIGS. 4A, 4B, 4C, and 4D, according to one or more exemplary embodiments. As previously mentioned, the first pixel may be a red pixel R, such that the emission layer of the first pixel may be emission layer 323R of the red pixel R and the auxiliary layer of the first pixel may be hole injection layer 321_R of the red pixel R.

[0050] Referring to FIGS. 5A, 5B, 5C, and 5D, the thin film layers 301, 302, R1, and R2 of the first color are formed by disposing the first mask 210a over substrate 300 and performing deposition as in FIGS. 5A and 5C. After the thin

film layers **301**, **302**, **R1**, and **R2** of the first color are formed, a process of correcting an offset by comparing the positions of the thin film layer **R1** for the first inspection and the central points **C1** and **C2** associated with the marks **M** is performed. The correction process is the same as described in FIGS. **4A** and **4C**, and, as such, duplicative descriptions are omitted to avoid obscuring exemplary embodiments.

[0051] The first mask **210a** is used to form the hole injection layer **321_R**, which is an auxiliary layer (referred to hereinafter as a first auxiliary layer) of the red pixel **R**. It is noted, however, that a portion of the first mask **210a** used to form the emission layer **323_R** of the red pixel **R** is different from a section portion of the first mask **210a** used to form the hole injection layer **321_R** of the red pixel. It is also contemplated that a different first mask may be utilized to form the hole injection layer **321_R** of the red pixel **R**.

[0052] As illustrated in FIG. **5A**, the first mask **210a** is disposed over substrate **300**. The first mask **210a** is rotated by 180 degrees from a position associated with forming the emission layer **323_R** of the red pixel **R**. To this end, the rotated configuration of first mask **210a** is aligned with respect to the substrate **300**. That is, because the emission layer **323_R** of the red pixel **R** and the hole injection layer **321_R** of the red pixel **R** are thin film layers of the same pattern formed in the same position, the first mask **210a** of the same kind as the one used to form the emission layer **323_R** of the red pixel **R** may be used. Also because a pattern of the same shape as the one used to form the emission layer **323_R** of the red pixel **R** is repeatedly formed, the pattern may be maintained without change even when the first mask **210a** is rotated by 180 degrees. It is noted, however, that some offset may occur, but this offset may be determined and adjusted for via the next offset correction process.

[0053] When the first mask **210a** is rotated by 180 degrees, the above-described pattern **R2'** for inspecting the second pixel position corresponds to a position that may be compared with the mark **M** on the substrate **300**. In this manner, when deposition is performed, the thin film layers **301**, **302**, **R1**, and **R2** associated with the first auxiliary layer are formed as in FIG. **5D**. The thin film layer corresponding to the active area **301** will become the hole injection layer **321_R** of the red pixel **R**.

[0054] To inspect whether the thin film layers **301**, **302**, **R1**, and **R2** of the first auxiliary layer including the hole injection layer **321_R** of the red pixel **R** are accurately formed, the positions of the thin film layer **R2** of the third inspection and the central points **C1** and **C2** of the marks **M** may be compared with each other as described with reference to FIG. **3**. When it is determined that an offset of the first mask **210a** exists as a result of the comparison, the position of the first mask **210a** may be adjusted so that the offset may be canceled (or at least reduced) when the next thin film layers **301**, **302**, **R1**, and **R2** of the first auxiliary layer are formed.

[0055] Although the formation of the emission layer **323_R** of the red pixel **R** has been described first for descriptive convenience, the hole injection layer **321_R** of the red pixel **R** is formed before the emission layer **323_R** of the red pixel **R** based on the stacking sequence as described in association with FIG. **2**. In this manner, because the emission layers **323_R** of the red pixels **R**, the emission layers **323_B** of the blue pixels **B**, and the hole injection layers **321_R** of the red pixels **R** may be formed using the

same first mask **210a**, the potential for error decreases, as well as reducing in manufacturing time and cost. Moreover, it is easier to manage the overall manufacturing process.

[0056] FIGS. **6A**, **6B**, **6C**, and **6D** illustrate a method of patterning an emission layer of a third pixel and an auxiliary layer of the third pixel using a second mask, according to one or more exemplary embodiments. For instance, the emission layer of the third pixel may be emission layer **323_G** of a green pixel **G** and the auxiliary layer of the third pixel may be hole injection layer **321_G** of the green pixel **G**. The second mask will be referred to as mask **210b**.

[0057] Given that the emission layer **323_G** and the hole injection layer **321_G** of the green pixel **G** have a pattern different from that of the red pixel **R** and the blue pixel **B**, the emission layer **323_G** and the hole injection layer **321_G** are not formed by shifting or rotating the first mask **210a**, but, instead, are formed using a second mask **210b** having second pixel patterns in the active area **213** and the dummy area **214**, and patterns **G1'**, **G2'** for inspecting third and fourth pixel positions for the green pixel **G**.

[0058] According to one or more exemplary embodiments, the second mask **210b** is aligned on the substrate **300** as in FIG. **6A** and deposition is performed. Thin film layers **303**, **304**, **G1**, and **G2** of a green (**G**) color (referred to hereinafter as third color) are formed on the substrate **300** as in FIG. **6C**. An active area **303** and a dummy area **304** of the thin film layer of the third color are formed on areas of the substrate **300** that correspond to the second pixel patterns in the active area **213** and the dummy area **214** of the second mask **210b**, respectively. The thin film layers **G1** and **G2** for fourth and fifth inspection are formed on areas that correspond to the patterns **G1'** and **G2'** for inspecting the third and fourth pixel positions of the second mask **210b**, respectively. The thin film layer corresponding to the active area **303** will become the emission layer **323_G** of the green pixel **G**.

[0059] To inspect whether the thin film layers **303**, **304**, **G1**, and **G2** of the third color including the emission layer **323_G** of the green pixel **G** are accurately formed, the positions of the thin film layer **G1** of the fourth inspection and the central points **C1** and **C2** associated with the marks **M** are compared with each other as described with reference to FIG. **3**. When it is determined that an offset of the second mask **210b** exists as a result of the comparison, the position of the second mask **210b** may be adjusted so that the offset may be canceled (or at least reduced) when the next thin film layers **303**, **304**, **G1**, and **G2** of the third color are formed.

[0060] The second mask **210b** may also be utilized to form the hole injection layer **321_G**, which is an auxiliary layer (referred to hereinafter as a second auxiliary layer) of the green pixel **G**. It is contemplated, however, that the second mask **210b** used when the emission layer **323_G** of the green pixel **G** is formed may not be used when the hole injection layer **321_G** of the green pixel **G** is formed, but, instead, another second mask **210b** may be used.

[0061] As illustrated in FIG. **6A**, the second mask **210b** is disposed over substrate **300**. The second mask **210b** is rotated by 180 degrees from a position of forming the emission layer **323_G** of the green pixel **G** and aligned with respect to the substrate **300**. That is, because the emission layer **323_G** of the green pixel **G** and the hole injection layer **321_G** of the green pixel **G** are thin film layers having the same pattern formed in the same position, the second mask **210b** may be used. Further, because a pattern of the same shape is repeatedly formed, the pattern may be maintained

without change even when the second mask **210b** is rotated by 180 degrees. It is noted, however, that some offset may occur, but this offset may be adjusted via the next offset correction process.

[0062] Moreover, when the second mask **210b** is rotated by 180 degrees, the above-described pattern **G2'** for inspecting the fifth pixel position corresponds to a position that may be compared with the mark **M** on the substrate **300**. In this manner, when deposition is performed, the thin film layers **303**, **304**, **G1**, and **G2** of the second auxiliary layer may be formed as in FIG. 6D. The thin film layer corresponding to the active area **303** will become the hole injection layer **321_G** of the green pixel **G**.

[0063] To inspect whether the thin film layers **303**, **304**, **G1**, and **G2** of the second auxiliary layer including the hole injection layer **321_G** of the green pixel **G** are accurately formed, the positions of the thin film layer **G2** of the fifth inspection and the central points **C1** and **C2** associated with the marks **M** are compared with each other as described with reference to FIG. 3. When it is determined that an offset of the second mask **210b** exists as a result of the comparison, the position of the second mask **210b** may be adjusted so that the offset may be canceled (or at least reduced) when the next thin film layers **303**, **304**, **G1**, and **G2** of the second auxiliary layer are formed.

[0064] Although the formation of the emission layer **323_G** of the green pixel **G** has been described first for descriptive convenience, the hole injection layer **321_G** of the green pixel **G** is formed before the emission layer **323_G** of the green pixel **G** based on a stacking sequence as described in association with FIG. 2. In this manner, because the emission layer **323_G** of the green pixel **G** and the hole injection layer **321_G** of the green pixel **G** may be formed using the same second mask **210b**, the potential for error decreases, as well as reducing in manufacturing time and cost. Moreover, it is easier to manage the overall manufacturing process.

[0065] Accordingly, all of the emission layers **323_R**, **323_G**, and **323_B** of the red, green, and blue pixels **R**, **G**, **B**, and the hole injection layers **321_R** and **321_G** of the red and green pixels **R** and **G** may be formed using two masks, e.g., the first mask **210a** and the second mask **210b**, in two different orientations. In this manner, exemplary embodiments enable the potential for error to decrease, as well as enable reductions in manufacturing time and cost. Moreover, it is easier to manage the overall manufacturing process and productivity may increase.

[0066] Although certain exemplary embodiments and implementations have been described herein, other embodiments and modifications will be apparent from this description. Accordingly, the inventive concept is not limited to such embodiments, but rather to the broader scope of the presented claims and various obvious modifications and equivalent arrangements.

What is claimed is:

1. A method for pixel patterning and pixel position inspection of an organic light-emitting display device, the method comprising:

forming, on a substrate using a first mask, a thin film layer of a first color corresponding to a first pixel pattern and a first pixel positioning pattern for inspecting a position of a first pixel;

shifting, by a determined pitch, the first mask from a position associated with forming the thin film layer of the first color;

aligning the shifted first mask with respect to the substrate; and

forming, on the substrate using the shifted first mask, a thin film layer of a second color corresponding to the first pixel pattern and another first pixel positioning pattern for inspecting a position of a second pixel.

2. The method of claim 1, wherein:

the first pixel pattern comprises a first area in a central portion and a second area disposed outside the first area; and

the determined pitch is less than or equal to a width of the second area in a direction of the shifting.

3. The method of claim 2, wherein:

shapes of the thin film layer of the first color and the thin film layer of the second color are equivalent; and the shapes are spaced apart by the determined pitch.

4. The method of claim 1, further comprising:

inspecting position accuracy of the thin film layer of the first color based on a position of a thin film layer for a first inspection formed to correspond to the first pixel positioning pattern; and

inspecting position accuracy of the thin film layer of the second color based on a position of a thin film layer for a second inspection formed to correspond to the another first pixel positioning pattern.

5. The method of claim 4, wherein a second pixel positioning pattern for inspecting the position of the second pixel is formed on the substrate in a position different from a position of the first pixel positioning pattern for inspecting the position of the first pixel.

6. The method of claim 5, further comprising:

rotating, prior to forming the thin film layer of the first color, the first mask by a determined angle, the rotated first mask being utilized to form the thin film layer of the first color; and

forming, prior to rotating the first mask, a thin film layer of a first auxiliary layer corresponding to the first pixel pattern and still another first pixel positioning pattern for inspecting the position of the first pixel.

7. The method of claim 6, wherein:

the thin film layer of the first color and the thin film layer of the first auxiliary layer are formed overlapping each other in a same position on the substrate;

the thin film layer for the first inspection and a thin film layer for a third inspection formed to correspond to the another first pixel positioning pattern for inspecting the position of the second pixel are formed at different positions.

8. The method of claim 7, further comprising:

inspecting position accuracy of the thin film layer of the first auxiliary layer based on a position of the thin film layer for the third inspection.

9. The method of claim 8, wherein:

the thin film layer of the first color comprises an emission layer of a red pixel;

the thin film layer of the second color comprises an emission layer of a blue pixel; and

the thin film layer of the first auxiliary layer comprises a hole injection layer of the red pixel.

10. The method of claim 6, wherein the determined angle is 180 degrees.

11. The method of claim **1**, further comprising:
 disposing, over the substrate, a second mask in association with a position of a third pixel, the second mask comprising a second pixel pattern and a second pixel positioning pattern for inspecting a position of a fourth pixel;
 forming, on the substrate using the second mask, a thin film layer of a second auxiliary layer corresponding to the second pixel pattern and the second pixel positioning pattern for inspecting the position of the fourth pixel;
 rotating, after forming the thin film layer of the second auxiliary layer, the second mask by a determined angle; and
 forming, on the substrate using the rotated second mask, a thin film layer of a third color corresponding to the second pixel pattern and another second pixel positioning pattern for inspecting a position of the third pixel.

12. The method of claim **11**, wherein:
 the thin film layer of the third color and the thin film layer of the second auxiliary layer are formed overlapping each other in a same position on the substrate;
 a thin film layer for a fourth inspection formed to correspond to the another second pixel positioning pattern for inspecting the position of the third pixel, and a thin film layer for a fifth inspection formed to correspond to the second pixel positioning pattern for inspecting the position of the fourth pixel are formed at different positions.

13. The method of claim **12**, further comprising:
 inspecting position accuracy of the thin film layer of the third color based on a position of the thin film layer of the fourth inspection; and
 inspecting position accuracy of the thin film layer of the second auxiliary layer based on a position of the thin film layer of the fifth inspection.

14. The method of claim **11**, wherein:
 the thin film layer of the third color comprises an emission layer of a green pixel; and

the thin film layer of the second auxiliary layer comprises a hole injection layer of the green pixel.

15. The method of claim **11**, wherein the determined angle is 180 degrees.

16. A pixel patterning mask for an organic light-emitting display device, comprising:

a pixel pattern;

a first inspection pattern for inspecting a first pixel position, the first inspection pattern being configured to facilitate measurement of position accuracy of a thin film layer formed on a substrate via the pixel pattern; and

a second inspection pattern for inspecting a second pixel position, the second inspection pattern being configured to facilitate measurement of position accuracy of a thin film layer formed on the substrate via the pixel pattern,

wherein the second inspection pattern is formed in a different position than the first inspection pattern.

17. The pixel patterning mask of claim **16**, wherein:
 the pixel pattern comprises a first area in a central portion of the pixel patterning mask and a second area disposed outside of the first area; and

the first area is associated with formation of an active area of an organic light emitting display device.

18. The pixel patterning mask of claim **17**, wherein:
 the pixel pattern comprises two-fold symmetry;
 the first inspection pattern and the second inspection pattern are aligned adjacent to each other on a first side of the pixel patterning mask; and
 the first inspection pattern and the second inspection pattern are disposed outside the pixel pattern.

19. The method of claim **1**, wherein the first pixel pattern comprising two-fold symmetry.

20. The method of claim **11**, wherein the second pixel pattern comprises two-fold symmetry.

* * * * *

专利名称(译)	掩模，检查和调整掩模位置的方法，以及利用掩模对有机发光显示装置的像素进行图案化的方法		
公开(公告)号	US20160343944A1	公开(公告)日	2016-11-24
申请号	US14/883989	申请日	2015-10-15
[标]申请(专利权)人(译)	三星显示有限公司		
申请(专利权)人(译)	三星DISPLAY CO., LTD.		
当前申请(专利权)人(译)	三星DISPLAY CO., LTD.		
[标]发明人	LEE SANGSHIN HA DONGJIN KANG MINGOO KWON OHSEOB YI SANGMIN		
发明人	LEE, SANGSHIN HA, DONGJIN KANG, MINGOO KWON, OHSEOB YI, SANGMIN		
IPC分类号	H01L51/00 H01L27/32 H01L51/56		
CPC分类号	H01L51/0011 H01L51/56 H01L51/5088 H01L51/5012 H01L27/3211 H01L51/0031 H01L27/3223		
优先权	1020150069351 2015-05-19 KR		
其他公开文献	US9705082		
外部链接	Espacenet USPTO		

摘要(译)

一种用于有机发光显示装置的像素图案化和像素位置检查的方法包括：在基板上使用第一掩模形成对应于第一像素图案的第一颜色的薄膜层和用于检查第一像素的位置；从与形成所述第一颜色的薄膜层相关联的位置将所述第一掩模移动确定的间距；将移位的第一掩模相对于衬底对准；以及使用移位的第一掩模在所述衬底上形成对应于所述第一像素图案的第二颜色的薄膜层和用于检查第二像素的位置的另一第一像素定位图案。

